

Milkotronic Ltd

LACTOSCAN SP

MILK ANALYZER

Wide LCD display – 4 lines x 16 characters

Plastic box

Operation manual

Switching Adapter

- **Input:** 100 - 240 V ~1.6 A max.
50-60 Hz
- **Output:** +12 V  3 A min.
- **Output power:** 36 - 42 W

Measurement modes

- cow milk
- sheep milk
- UHT milk
- goat milk
- buffalo milk
- cream
- whey
- recovered milk
- other /pasteurized milk/

CAUTION!

Keep the switching adapter dry!
Please, read and follow strictly all the instructions in the manual.

Due to continuous improvement in the device, information contained in this manual is subject to change without notice. Contact the company-producer for revisions and corrections

4, Narodni Buditeli Str.
8900 Nova Zagora
BULGARIA
Phone/Fax: + 359 457 67082
e-mail: office@lactoscan.com
www.lactoscan.com
www.milkotronic.com

SAFETY INSTRUCTIONS

- 1. Read this manual carefully and make sure that you understand all the instructions.**
- 2. For safety purposes the device is equipped with grounded power cable. If there is no grounded electrical outlet where the device will be used, please, install such before using the device.**
- 3. Place the device on leveled and stable plate. In case it falls or is severely shocked it may be damaged.**
- 4. Connect to the electrical network in such a way that the power cable to stay away from the side for accessing the device and not to be stepped on.**
- 5. Every time before cleaning the device switch it off and unplug it from the electrical outlet. The device has to remain unplugged till the cleaning completion.**
- 6. Do not disassemble the unit in order to avoid possible electrical shock. In case of malfunction contact your local dealer.**
- 7. Handle the liquids the device works with carefully, following all the instructions for their preparation.**
- 8. Place the switching adaptor in such a way as to be protected from overflow and spillage of liquids.**

PARTS AND ACCESSORIES

In the table below the standard delivery configuration of the milk analyzer is listed:

No	Description	Item No	pcs
1.	Ultrasonic portable milk analyzer	LSSP001	1
1 sample measurement time		60 sec	<input type="checkbox"/>
		30 sec	<input type="checkbox"/>
2.	Operation manual	LSSP002	1
3.	Plastic sample holder	LSSP003	2
4.	Spare Pipes	LSSP004	2
5.	12 V DC Power Supply Cable	LSSP005	1
6.	Alkaline cleaning solution Lactodaily	100 g	1
7.	Acidic cleaning solution Lactoweekly	100 g	1

In the table below the milk analyzer spares and accessories, which are delivered on customers request are listed:

No	Description	Item No	pcs	<input checked="" type="checkbox"/> / <input type="checkbox"/>
	a) included in the set: <input checked="" type="checkbox"/> b) not included in the set (may be additionally bought): <input type="checkbox"/>			
8.	RS232 Interface Cable - Analyser-IBM PC	LSSP006		<input type="checkbox"/>
9.	Service Pack - CD	LSSP007		<input type="checkbox"/>
10.	pH measuring system	LSS009	1	<input type="checkbox"/>
11.	pH probe with cable and holder	LSS010	1	<input type="checkbox"/>
12.	Buffer solution Ph 60 ml (pH7.00±0.01/20°C)	LSS011	1	<input type="checkbox"/>
13.	Buffer solution pH 60 ml (pH4.00±0.01/20°C)	LSS012	1	<input type="checkbox"/>
14.	Milk conductivity measuring system	LSS013	1	<input type="checkbox"/>
15.	Buffer solution conductivity 50 ml (5.02 (±5%) mS/cm (18±0.1°C)	LSS014	1	<input type="checkbox"/>
16.	Real time clock	LSS015	1	<input type="checkbox"/>
17.	ECS POS Serial Printer	LSS017	1	<input type="checkbox"/>
18.	12 V Serial Printer Power Supply Cable	LSS018	1	<input type="checkbox"/>
19.	RS232 Interface Cable - Milk Analyser – Serial Printer	LSS019	1	<input type="checkbox"/>

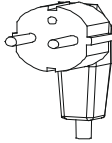
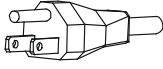
20.	Plug type		1	<input checked="" type="checkbox"/>
			1	<input type="checkbox"/>
21.	Spare O-ring for the pH probe		1	<input type="checkbox"/>

FUNCTION

The function of the milk analyzer is to make quick analysis of milk on fat (FAT), non-fat solids (SNF), proteins, lactose and water content percentages, temperature (°C), freezing point, salts, total solids, as well as density of one and the same sample directly after milking, at collecting and during processing.

2. TECHNICAL PARAMETERS

2.1. Working modes characteristics:

The program of the milk analyzer has 5 (five) working modes.

2.1.1. Measurement mode milk / dairy product – first type

2.1.2. Measurement mode milk / dairy product – second type

2.1.3. Measurement mode milk / dairy product – third type

These modes have been calibrated on customers' request for 3 milk types from the following: cow, sheep, UHT, buffalo, goat, camel milk, cream, ice cream mixtures, whey, recovered milk, etc. before leaving the production facilities and the text on the display will be for the corresponding types, as is indicated on page 2 Measurement modes.

2.1.4. Cleaning

2.1.5. Printing

2.2. Measuring range:

Fatfrom 0.01% to 25%
SNFfrom 3% to 15%
Density *from 1015 to 10 40 kg/m ³
Proteinsfrom 2% to 7%
Lactosefrom 0.01 % to 6 %
Water contentfrom 0 % to 70 %
Temperature of milkfrom 1°C to 40°C
Freezing pointfrom – 0,400 to – 0,700°C
Saltsfrom 0,4 to 1,5%
PH*from 0 to 14
Conductivity *from 3 to 14 [mS/cm]
Total Solids*from 0 to 50 %

* Option, on customers' request

** Density data are shown in an abbreviated form. For example 27.3 have to be understood as 1027.3 kg/m³. To determine the milk density, write down the result from the display and add 1000.

Example: result 21,20; density = 1000 + 21,20 = 1021,2 kg/m³

The abbreviated form of the density is used also when entering data for samples in working mode **Recalibrate**, for example:

If the measured sample density is 1034.5 kg/m³, then in the menu for entering the samples parameters used for calibration, across the parameter Den = , you have to enter 34.5.

**** Please, carefully read Appendix Freezing Point.

2.3. Accuracy:

Fat± 0.10%
SNF± 0.15%
Density± 0.3 kg/m ³
Proteins± 0.15%
Lactose± 0.20%
Water content± 3.0%
Temperature of milk± 1°C
Freezing point.....± 0.001°C
Salts± 0.05%
PH±0.05%
Conductivity±0.05

Total solids ± 0.17%

The difference between two sequent measurements of one and the same milk could not exceed the maximum permissible absolute error.

2.4 Correct ambient conditions:

Maximum permissible absolute error is guaranteed in case of normal ambient conditions:

Air temperature.....from 10°C to 40°C
Relative humidityfrom 30% to 80%
Power supply220V (110V)
Extent of contamination at normal environmental conditions.....2



Maximum permissible absolute error values in point 2.3 are in dependence on the correctness of the corresponding chemical method, used for component content determination. In point 2.3. are used the following reference methods: Gerber – for fat, gravimetric – for SNF, Kjeldahl – for protein. The boundary for maximum variation of repeatability when the power supply voltage is from +10 to – 15% from the nominal voltage values (220 V) have to be no more than 0.8 accuracy according point 2.3. The analyzer is used in conditions free of outer electrical and magnetic fields (except the magnetic field of the Earth) and vibrations.

2.5. Dimensions:

.....175/175/150 mm, mass 1,5 kg

2.6. Continuous working time:

.....non-stop

2.7 Milk sample volume per one measurement:

.....15 cm³ (= 25 ml)

Fig.1 Front panel

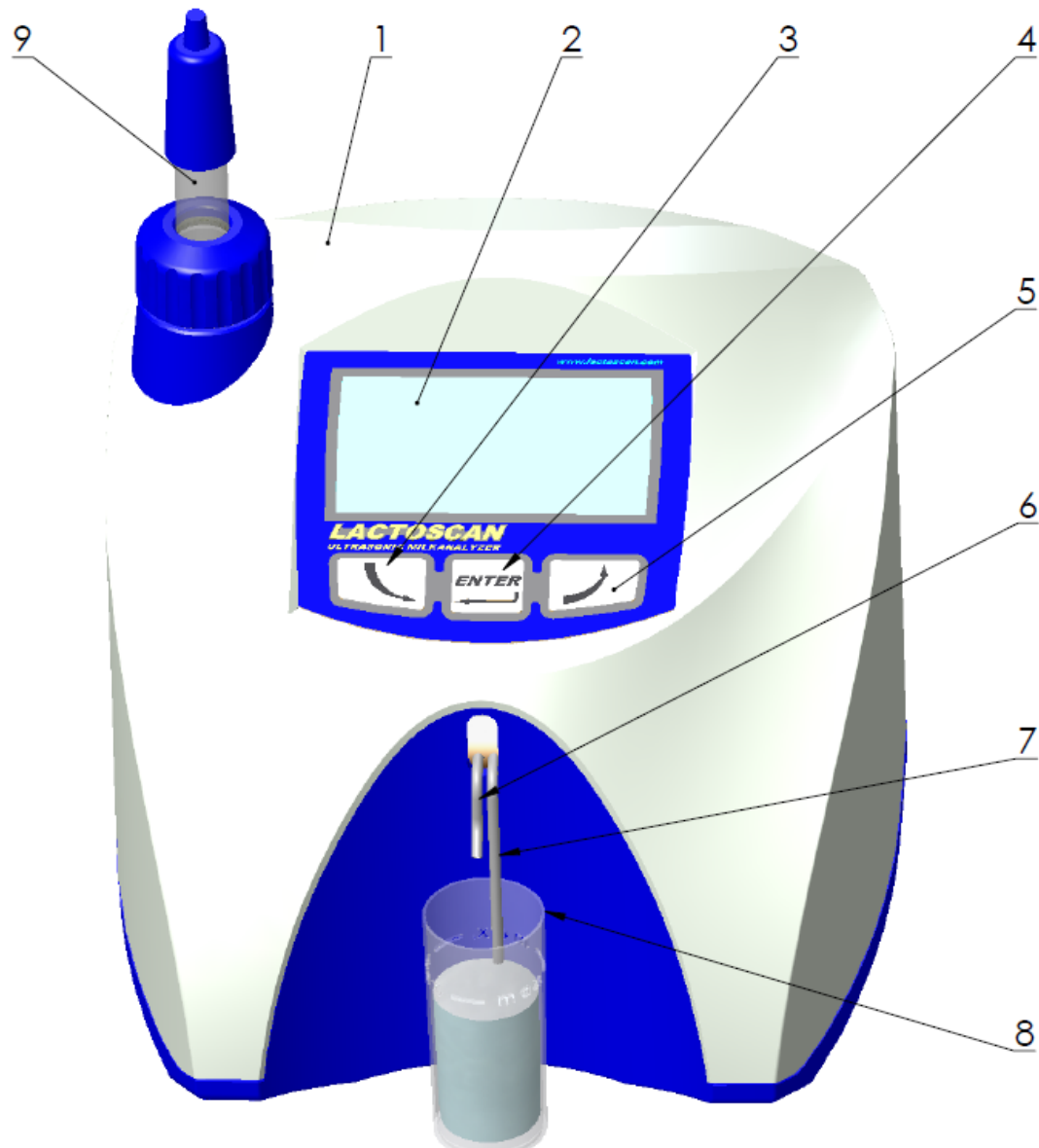

- 1. Upper cover
- 2. Wide Display
- 3. Button "Down"
- 4. Button "Enter"
- 5. Button "Up"

- 6. Output pipe
- 7. Input pipe
- 8. Sample holder
- 9. pH probe (option)

fig. 2 Back panel

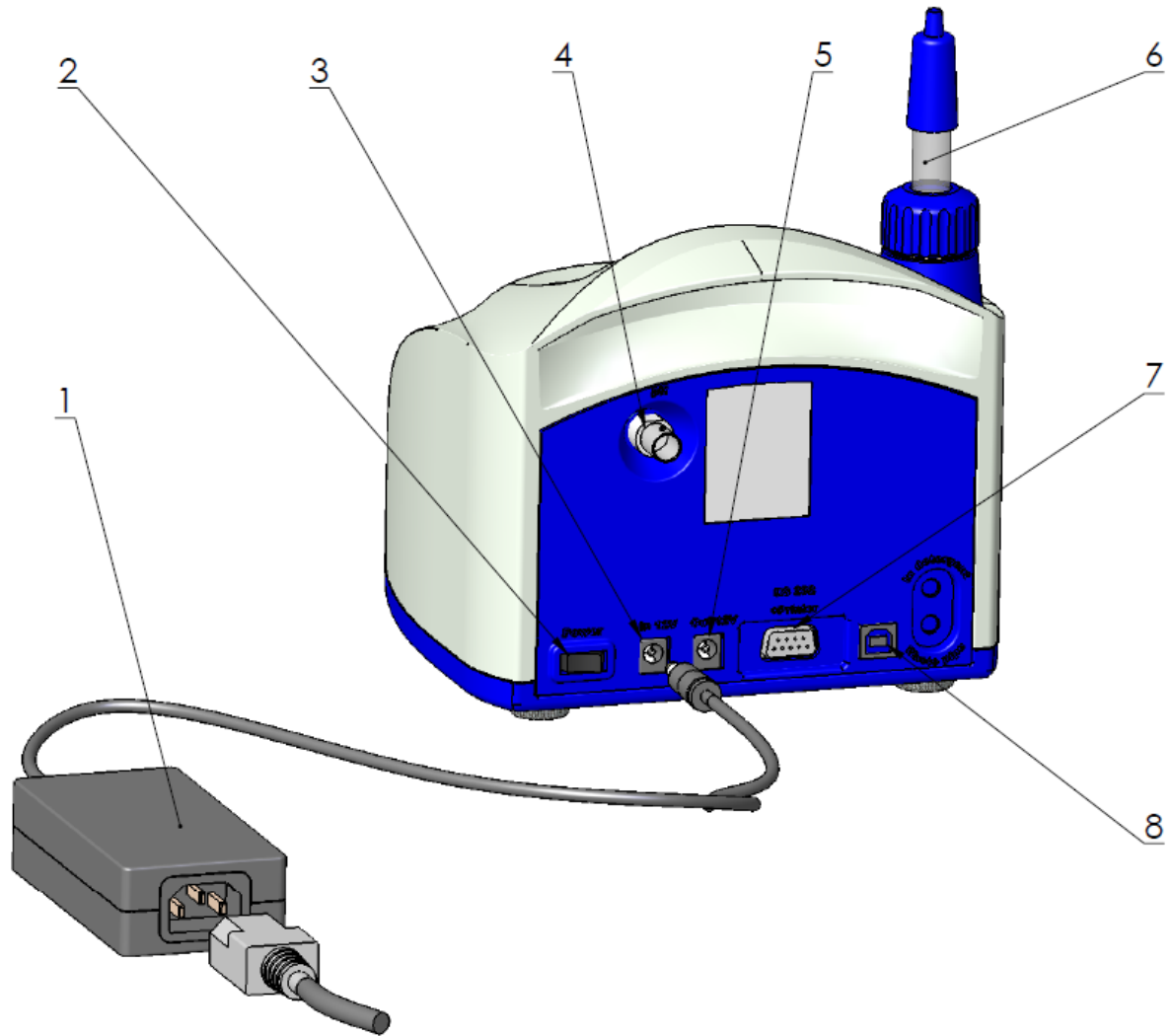

- 1 Switching adapter
- 2. Power switch
- 3. 12 V printer output
- 4. pH probe input (option)

- 5. 12 V input
- 6. pH probe (option)
- 7. Serial interface (RS232/ printer)
- 8. USB (option)

Fig. 4 **Peripherals connection**

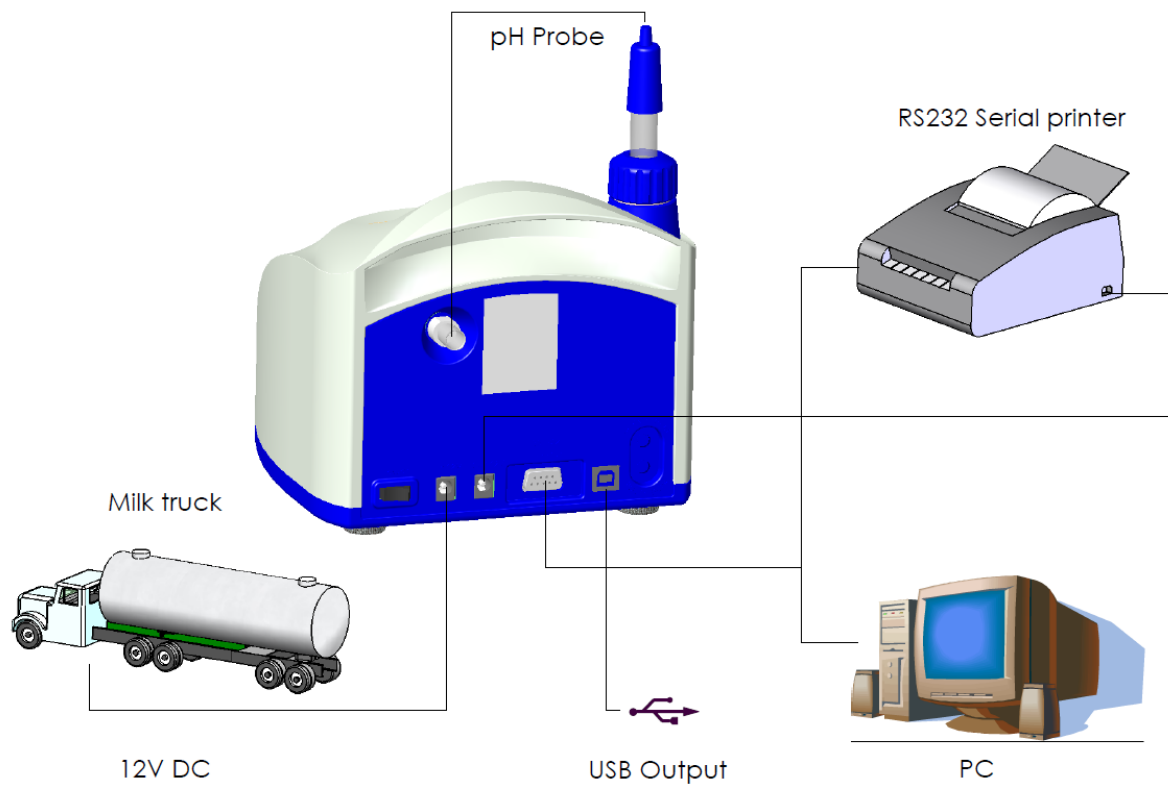
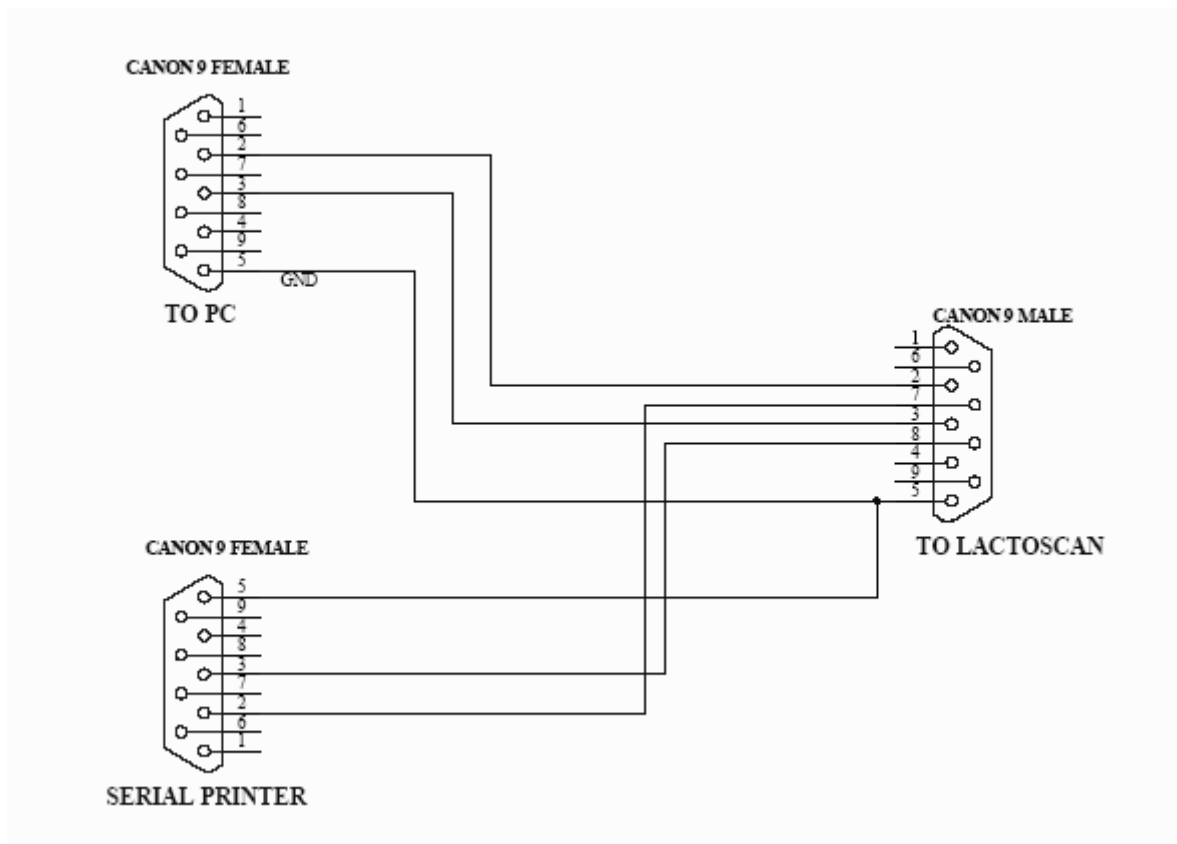

Fig. 4 Cable Description**90-1801-0008****RS232 Interface Cable - Milk Analyser – Serial Printer/ IBM PC**

The connection of the analyser with other devices via RS232 Interface is made through the coupling DB9 on the back panel of the device. In it can be plugged only the cable, supplied by the producer with the analyser (or produced by the customer as per above scheme). The coupling from the cable, marked on the scheme with „TO LACTOSCAN” must be plugged in the computer. If due to some reason is used an external cable USB to RS232 Converter (usually when working with a laptop the customers buy such cables from the market), it must be plugged in the coupling “TO PC” of the original cable, not directly in the device.

90-1801-0009**DC 12V Power Supply Milk Analyzer Cable**

1. GND
2. No connection
3. No connection
4. 12V DC

There's an option in the analyser – embedded USB interface (USB to RS232 Serial Converter) for connection with computer type IBM PC. It is

intended for connecting computers from laptop type, which have no RS 232 interface (COM Ports – DB9 Connector). This option may be available together with the standard RS232 – connector DB9, which always exists in the analyzers. At one and the same time, connection analyzer – computer, can be established only through one of the couplings – either only DB9, or only USB, i.e. analyzer could not be connected at one and the same time, using one of the interfaces with one and using the other interface to another, second computer. The coupling for this option (Printer Type) is at the back of the analyzer, next to the standard RS232 DB9 connector. Other USB devices like printers, keypads etc COULD NOT be connected to this coupling.

USB interface is based on the element MCP2200 of the company Microchip Technology Inc. – site: <http://www.microchip.com>. For establishing a connection through this interface a driver has to be installed for MCP2200 in the correspondent computer, which will be connected with the analyzer. Please, follow the procedure, from the Internet site of the producer: <http://www.microchip.com/wwwproducts/devices.aspx?ddocname=en546923>, by choosing the suitable for your operation system driver.

After installing the driver, choose the COM port, which will be used for the real communication. For Win XP it is done by executing the following commands: Start -> Settings -> Control panel -> System -> Hardware -> Device Manager -> Ports (COM and LPT) – Right Click -> Properties -> Port Settings -> Advanced -> COM Port Number. Choose Number 1 or if another number is chosen, for example 3, then, when working with the software tools, in the field COM Port (upper right corner), you have to set the new number of the port, in this case 3.

3. QUALIFICATION OF RAW MILK, THERMALLY TREATED MILK, OTHER DAIRY PRODUCTS AND DERIVATIVES

3.1. Taking samples and preparation for analysis

In order to receive reliable results in qualification of milk, dairy products and derivatives are needed: precise samples taking; correct samples storing (in need to be preserved); correct preparation before making measurement. The rules and requirements for this are described in details in *Appendix Preparing Samples*.

3.2. Making the measurement.

3.2.1. Preparing the analyzer for working mode

3.2.1.1. Put the analyzer on the working place, providing good ventilation and not in the vicinity of heat providing devices or sources. The temperature in the premises has to be in the boundaries 10-30°C.

3.2.1.2. Check if the power switch is in "0" position and that the outlet voltage complies with the voltage indicated on the rating plate of the analyzer. Connect the power supply cable to the electrical outlet.

3.2.1.3. Switch on the "**POWER**" button, which starts the identification procedure. For a short time the display shows the number of the software versions, for example:

Milk analyzer xxx
MB vers yy
Ser. N. xxxx

where:

Milk analyzer xxx is the time for measurement.

MB vers YY is the motherboard software version.

Ser. N. xxxx is the serial number – written on the rear panel of the analyzer.

These data are called analyzer's **Identity**



If in the process of exploitation there is a need to ask a question the company-producer, you have to send the data, written on the display during the above described initialization procedure i.e. the analyzer's identity.

3.2.1.4. Till the analyzer is prepared for work (at about 5 minutes) the following message is written on the display: "**Getting ready**". Above pointed time is in dependence of the environmental temperature and increases with decreasing the temperature.

3.2.1.5. When the device is ready for work the display shows: "**Ready to start**".

The analyzer is ready to make analysis in mode 1 (normally Cow)

3.2.1.6. If you want to pass to another mode press the button **Enter** and hold it pressed. The following message appears on the display:

**Release button to
start menu**

Release the button **Enter**. The display shows the possible working modes:

Milk selector
Cal1 – Cow
Cal2 – Sheep
Cal3 – UHT

Cleaning
Printing

Using "up" ▲ and "down" ▼ buttons, choose the working mode and press **Enter** in order to start it.

3.2.2. Making analysis

To start measurement: pour the preliminary prepared sample in the sample holder of the analyzer; put the sample holder in the recess of the analyzer; press the button **Enter**.

The analyzer sucks the milk, makes the measurement and returns the milk in the sample-holder. During the measurement the temperature of the sample is shown on the display.

Ignore the results received immediately after switching on the analyzer and after measuring distilled water. Make a second measurement with new portion of the same sample.

3.2.3. Displaying the results

3.2.3.1. When the measurement is finished, the sample returns in the sample-holder and the display shows the results. For example:

Results:	
F=ff.ff	S=ss.ss
D=dd.dd	P=pp.pp
L=ll.ll	W=ww.ww

Where:

F= ff.ff	- measured FAT in percentage;
S= ss.ss	- measured SNF in percentage;
D= dd.dd	- measured density in percentage;
P= pp.pp	- measured protein in percentage;
L= ll.ll	- measured lactose in percentage;
W= ww.ww	- measured sample's added water in percentage.

By pressing the button "Down" ▼ the display shows the second page, containing the results:

Page 2 Results:	
T=tt.tC	pH=pp.pp
FP=-0.fff	
s=0.sss	A=aa.aa

Where:

tt.tC	- sample's temperature;
pp.pp	- sample's pH result – if there is a pH probe connected;
-0.fff	- measured sample's freezing point;
0.sss	- measured solids values;
aa.aa	- measured total solids

By pressing the button "Up" ▲ display shows the third page with results:

Page 3 Results:
L=1.11

Where:

L= 11.11 - measured Lactose in %;

By pressing the buttons "up" ▲ and "down" ▼, the operator has the possibility to pass from one page result to another.



If the device has an embedded option "Conductivity" and "conductivity measurement" started, the result is shown on the display, showing the basic results replacing lactose results in the following way:

C=xx.xx

In this case the Lactose result is shown on a new page - Page 3 Results. xx.xx is the measured milk sample's conductivity in [mS/cm]. If the results are outside the limits for this type of sample (see table from the Appendix Conductivity measurement), the cursor flashes after the letter C, reminding that the sample is not correct. On the printout it is printed as !!!.

If the conductivity value is outside measuring range (2-14 mS/cm), the following message appears on the display:

C=OutRg (Out of Range), and on the printout there isn't any line with conductivity value.

3.2.3.2. Write down the results in the form. The results remain on the display till a new measurement is started. If the analyzer is connected to a computer or a printer, it sends the data to the computer or prints them.

Mode Printing

Serves for control of the printing. There are 2 variants:

-after switching on the power supply of the device. Then the analyser's parameters are printed (Identity).

-after completed measurement. Prints out the results from the last measurement.

4. CLEANING THE ANALYZER

4.1. Periodically cleaning (rinsing) the analyzer

It is done in the process of routine work of the analyzer. Its aim is to prevent drying up and adhesion of different milk components in the milk analyzer's measuring system.



The company-producer recommends usage of the chemicals, supplied with the analyzer – alkaline and acidic (Lactodaily and Lactoweekly). You may order them separately or together with the analyzer. Try to use only these chemicals for cleaning the analyzer.

In case you missed to order these chemicals, the alternative is to use alkaline and acidic cleaning solutions for dairy equipment by one the companies, producing such chemicals, as for example:

<http://www.diversesey.com>

<http://www.ecolab.com>

<http://www.calvatis.com>



Do not use chemicals not intended for usage in the milking systems or vessels in the dairy sector. Pay special attention to the concentration of the acidic chemical. **Increased concentration may damage the measuring sensor.**

4.1.1. Periodical cleaning frequency.

It is easy to understand what is the period on which the rinsing could be done as the analyzer reminds you when it is necessary. This is done by a sound signal in 1-second cycle after the set time intervals elapse:

- 55 min. after switching on the power supply of the analyser, but idle work;
- 15 min. after the last measurement of real milk sample.

*Idle Mode is that part of the standard working mode, when the analyser is not making measurements. There's embedded in the analyser system for measurement of the idle time. The idle time is measured starting from the last action of the operator. In dependence of it (what the operator last did), are taken decisions regarding the cleaning.

There are 2 options:

Option A: If the analyser:

1. Was only switched on but was not started in measurement mode,
2. Or the last action was cleaning,
3. Or the last action was measuring sample with very low Fat (similar to water)

Then the signal for cleaning is started after 55 min.

Option B: If the last thing done with the analyser was measurement of normal milk sample, the signal for cleaning is started after 15 min.

After cleaning completion, new measurement takes place in above described time intervals.

The following message appears on the display:

**Time to start
cleaning**

4.1.2. Making the rinsing

After above message is received put in the recess of the analyzer a glass filled with 120 ml water (in case 1 from p.4.1.1.) or alkaline cleaning solution (in case 2 from p.4.1.1.).

Press **Enter** to start the rinsing mode.

In this mode the analyzer makes 3 cycles and stops.

Already used solution is poured out of the analyser. Now the device is ready for the next measurement. In case of doubt that the analyzer is still not well cleaned, the procedure Cleaning may be executed repeatedly.

4.2. Complete cleaning

4.2.1. Complete cleaning frequency

This cleaning is done after finishing the work with the analyzer at the end of the working day or if it is obvious that the measuring system of the analyzer is contaminated in case of intensive work with it. It is done with alkaline cleaning solution.

Preparation of 3 % alkaline solution of Lactodaily for circulation cleaning in the milk analyzer:

1. Take the package 100 g concentrated chemical Lactodaily
2. In appropriate vessel (for example bucket) pour 1 l water.
3. Add the powder and then again water up to 3 l.



For a single cleaning cycle you need only 25 ml cleaning solution. We recommend you to prepare working solutions of cleaning chemicals, enough for normal work for 1 week, because, during their stay unused, the working solutions lose their strength and also is difficult to store them.

Then follow the instruction for milk analyzer cleaning.

4.2.2. Cleaning

4.2.2.1. Rinsing milk residues

Fill in the glass with water. Put it in the recess of the analyser and start command Cleaning from the main menu. After finishing it pour out the contaminated water.

4.2.2.2. Cleaning with alkaline cleaning solution

Fill in the glass with warm (50-60 C) alkaline cleaning solution. Put it in the recess of the analyser and start the command Cleaning from the main menu. After finishing it, pour out the contaminated liquid.

4.2.2.3. Rinsing with water

Fill in the glass with water. Put it in the recess of the analyser and start command Cleaning from the main menu. After finishing it pour out the contaminated water. Now the device is ready for work.

4.2.2.4. Cleaning with acidic solution

It is recommended to be done every day.

Preparation of 3 % acidic solution of Lactoweekly for circulation cleaning in the milk analyzer:

1. Take the package 100 g concentrated chemical Lactodaily
2. In appropriate vessel (for example bucket) pour 1 l water.
3. Add the chemical and then again water up to 3 l.

Fig. 5 Labels for the cleaning chemicals

L a c t o w e e k l y Acidic cleaner and descaler	L a c t o d a i l y Alkaline detergent sanitizer with QAC.
<p>General Description: Low foaming powder product for acidic cleaning of all types milk analysers Lactoscan according their instructions. The product very effectively removes milk stone and hard water deposits thus improving hygienic status of all milking equipment. May be used for manual application as well as for automatic circulation cleaning.</p> <p>Application: Automatic application: 1. Pre-rinse with sufficient water to remove milk residues 2. Circulate a 1% (10 g/l) cleaning solution for 10 to 20 minutes at a temperature above 40°C 3. Rinse thoroughly with tap water.</p> <p>Manual application: Use 0,5 - 1,0% (5 - 10g/l) after sufficient pre-rinsing at 30 to 40°C, soak for at least 10 minutes Rinse thoroughly with tap water. Determination of concentration Titration of p-value with 1 N sodium hydroxide Special instructions: Keep container closed and away from humidity.</p>	<p>Material compatibility: Stainless steel is not affected by the solution. Aluminium is slightly etched.</p> <p>Physical and chemical properties: Appearance: white powder Odour: faintly of surfactant pH-value (1%) 1,6 p-value: 4,5 Composition: Sulfamic acid, phosphates, sulfates, surfactant, defoamer Hazard label: Xi, irritant</p> <p>Risks: R 36/38 - Irritating to eyes and skin R 52/53 - Harmful to aquatic organisms, may cause long-term adverse effects in the aquatic environment For health and safety information, refer to the Safety Data Sheet (SDS) for this product</p>
<p>General Description: Alkaline powder product with QAC for combined cleaning and disinfecting of all types milk analysers Lactoscan according their instructions. Suitable for all water conditions and may be used for manual application as well as for automatic circulation cleaning. Non corrosive on most materials and mild to skin.</p> <p>Application: Automatic application: 1. Pre-rinse with sufficient water to remove milk residues 2. Circulate a 1% (10 g/l) cleaning solution for 10 to 20 minutes at a temperature above 40°C 3. Rinse thoroughly with tap water.</p> <p>Manual application: Use 0,5 - 1,0% (5 - 10g/l) after sufficient pre-rinsing at 30 to 40°C, soak for at least 10 minutes Rinse thoroughly with tap water. Determination of concentration Titration of p-value with 1 N Hydrochloric acid Special instructions: Keep container closed and away from humidity.</p>	<p>Material Compatibility: Stainless steel and Aluminium are not affected by the solution.</p> <p>Physical and chemical properties: Appearance: white powder Odour: faintly of surfactant pH-value (1%) 11,5 p-value: 4,5 Composition: Carbonates, phosphates, silicates, surfactants, defoamer, disinfectant</p> <p>Hazard label: Xi, irritant</p> <p>Risks: R 36/38 - Irritating to eyes and skin For health and safety information, refer to the Safety Data Sheet (SDS) for this</p>

The following procedure is executed:

1. Rinsing the milk residues:

Fill in the glass with water. Put it in the recess of the analyser and start command Cleaning from the main menu. After finishing it pour out the contaminated water.

2. Cleaning with acidic solution

Fill in the glass with warm (50-60 C) acidic cleaning solution. Put it in the recess of the analyser and start the command Cleaning from the main menu. After finishing it, pour out the contaminated liquid.

3. Rinsing with water

Fill in the glass with water. Put it in the recess of the analyser and start command Cleaning from the main menu. After finishing it pour out the contaminated water. Now the device is ready for work.



Please, pay attention that, when the analysers gives a signal for need of cleaning 15 min after the last measurement of real milk samples or 55 min. after being powered and not used, cleaning is made ONLY with alkaline solution in concentration 1-3%.

During the basic/final cleaning sequence is: alkaline solution – water – acidic solution - water

IMPORTANT
THE MAIN REASON FOR MALFUNCTIONING OF THE
DEVICE IS THE BAD CLEANING OF THE SYSTEM AFTER
MAKING ANALYSIS.

In case of malfunction due to the bad cleaning of the
analyser your guarantee is not valid anymore and any
repair has to be paid.

4.3. Peristaltic pump service

Fig.6 Peristaltic pump

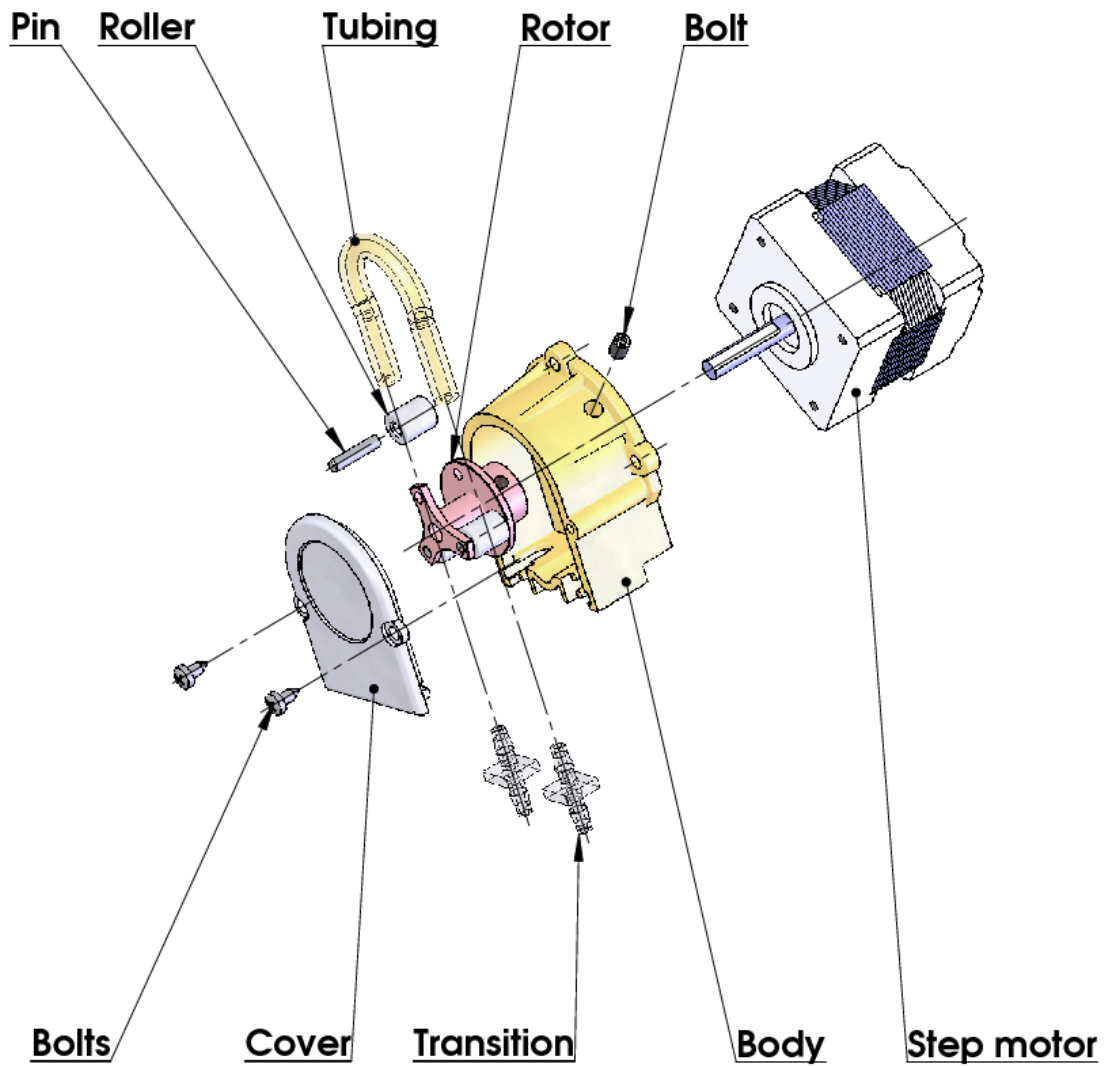

5. POSSIBLE MALFUNCTIONS AND ERROR MESSAGES, TROUBLESHOOTING

In the table below are described the possible malfunctions during the milk analyzer's exploitation and ways for their repair/remedy. If the problem persists after all recommended measures are taken, please, connect the nearest service center for help. Do not forget to tell the analyser's identity.



To receive the analyzer's identity, refer to point 3.2.1.3.

Error message	Possible problem /cause	Repair/remedy
2 MA overheated Accompanied by a continuous sound signal	Overheated milk analyzer	Immediately switch off the analyzer. Pay attention the analyzer to be situated away from direct sunlight or heating devices. Wait 5-10 minutes the device to cool down or to be normalized the ambient temperature and switch it on again.
3 Empty Camera	Insufficient quantity of the milk sample sucked in the system or air in the sample	The analyzer is ready to measure the next sample. In order to avoid the future appearance of the same error message, please, check the following: <ul style="list-style-type: none"> - The sample is prepared according the instructions and there aren't air bubbles in it. - There is a real suction of the sample after starting measurement, i.e. it is obvious that the level of the milk sample in the sample holder decreases. In other case – there is damage in the suction system. - Avoid the end of the suction pipe to be above the surface of the liquid (not dipped enough). - Avoid curdling of the milk sample. Clean immediately if there is a sample curdled in the system. - In mode Measurement, after starting the measurement, remove the sample holder and see if there is no milk poured

		back in the sample holder.
4 Sample Overheat	Sucked overheated sample	<p>The analyzer is ready to measure the next sample. In order to avoid the future appearance of the same error message, please, check the following:</p> <ul style="list-style-type: none"> -The sample is prepared according the instructions and its temperature does not exceed the maximum permissible sample's temperature. -Complete the procedure for checking the analyzer in case of error message Empty Camera.

6. MAKING CORRECTIONS AND RECALLIBRATION OF THE DEVICE

In the process of work with the analyser there is a possibility the results to start differing between the data for some of the measuring parameters when measured with the milk analyzer and the corresponding reference method of analysis (Gerber for fat, Kjeldhal for proteins etc). In order to establish the possible discrepancy and to correct the readings of the milk analyser do the following:

6.1. Taking samples and preparation of samples for checking the accuracy of the milk analyser, making corrections and recalibration

This is a basic moment for the correct checking the accuracy of the analyser and for making correct and precise correction and calibration. It is accomplished according Appendix Sampling and preparation of samples for verification the accuracy of the milk analyzer, making corrections and recalibration.

6.2. Determination the type of the discrepancy:

6.2.1. Making measurements

Make measurements with different samples (not less than 3) with known values of a separate parameter (for example fat content), determined by the known reference methods of analysis (for example Gerber's method for determination of fat content). For more accuracy it is recommended among these samples to be also such with values, close to the lowest and highest bounds for the measured parameters.

Make 5-time measurement for each of the samples. Calculate the average value for each sample parameter, without taking into consideration the first measurement for each sample.

6.2.2. Analysing the measurement results

Make comparison between the values of the parameter from the reference sample and measured with the analyser. Make analysis of the difference received.

6.2.2.1. If the received differences are relatively constant value for samples with different content of the analysed parameter, it is necessary to make correction.

For example

M% of the reference samples:	2,20	3,00	3,80	4,60	5,20
M% average when measuring with the analyser:	<u>2,38</u>	<u>3,17</u>	<u>4,01</u>	<u>4,79</u>	<u>5,42</u>
Difference:	0,18	0,17	0,21	0,19	0,22

Conclusion: the difference is relatively constant value and correction is possible to be done with – 0,2 % (see Corrections, p6.3.3)

6.2.2.2. If the differences are not a constant value it is necessary recalibration to be done.

For example.

M% of the reference samples:	2,20	3,00	3,80	4,60	5,20
M% when measured with the analyser:	<u>2,02</u>	<u>2,93</u>	<u>3,76</u>	<u>4,75</u>	<u>5,44</u>
Difference:	-0,18	-0,07	-0,04	0,15	0,24

Conclusion: It is obvious that the difference is variable value and recalibration have to be done (See Recalibration, p.6.4).

6.3. Making corrections

6.3.1. Possible corrections, limits and changing steps

Every parameter from each calibration may be separately corrected. Below is the table with possible corrections, limits and changing steps:

Parameter	Increasing	Decreasing	Step
FAT	0.95%	0.95%	0.01%
SNF	4.75%	4.75%	0.05%
Density	4.75%	4.75%	0.05%
Lactose	0.95%	0.95%	0.01%
Salts	0.95%	0.95%	0.01%
Proteins	0.95%	0.95%	0.01%
Added water	9.00%	9.00%	1.00%
Sample's temperature	9.90°C	9.90°C	0.1°C

6.3.2. Preparing the analyzer for mode Corrections

6.3.2.1. Press the button **Enter** and without releasing it switch on the power supply of the device, wait for the starting identification messages and release the button after the following message appears on the display:

**Release button
to start setup**

After releasing the button on the display is shown:

Setup Menu

followed by possible to be entered by the operator menus:

**Special modes
Corrections
Settings**

**Tests
pH & Co Meter
Accessories
Exit**

6.3.2.2. By using buttons “**up**” ▲ and “**down**” ▼ position on **Corrections** and press **Enter**.

6.3.3. Making correction

6.3.3.1 Determining the correction mode

When starting **Corrections**, the following appears on the display:

**Corrections:
Measurement
Temperature
Cond measure
Exit**

Position on **Measurement** and press **Enter**. By using buttons “up”▲ and”down”▼position on the corresponding calibration (for example **Correction 1 – cow**) and press **Enter**.

6.3.3.2. Choosing correction parameter

After choosing calibration mode the display shows the following:

Cal1 Cow Param:Fat Correct=00.00 Edit OK Next
--

Using the buttons “up”▲ and ”down”▼position on the action you want to take (for example Edit) and press the button **Enter**.

6.3.3.3. Making correction

After choosing parameter (for example fat) the display shows the following:

Cal:.... Param:.... Correct= 00,00 - OK +
--

Using the buttons “up”▲ and ”down”▼is possible to increase or decrease the value of the measured parameter in the above pointed limits. Leaving this mode means saving the correction value and activating it.

6.3.3.4. Making verification

After the corrections are made put the milk analyser in working mode and make several times measurement of reference samples with known values of the corrected parameter. If the difference between the values of the parameter from the reference methods and milkanalyser are in the limits for the parameter it may be considered that the correction is successfully made. If the discrepancy between the measurements from the milk analyser and classical methods is bigger than is necessary to make second correction according above described way.

If after the second correction the results are unsatisfactory we recommend making a calibration of the analyser. In dependence of the conditions and your requirements you may make the calibration using a personal computer

type IBM PC and the company's calibration program or autonomous - by recalibration.



When making corrections or calibrations be 100% sure in the accuracy of the reference methods result.

6.4. Recalibrating the milk analyser

6.4.1. Running the analyser in mode Recalibrate

6.4.1.1. Press the button **Enter** and without releasing it switch on the power supply of the device, wait for the starting identification messages and release the button after the following message appears on the display:

**Release button
to start setup**

After releasing the button on the display is shown:

Setup menu

Followed by the possible to be entered by the operator menus:

**Special modes
Corrections
Settings**

**Tests
pH & Co Meter
Accessories
Exit**

6.4.1.2. By using buttons “up” ▲ and “down” ▼ position on **Settings** and press button **Enter**.

6.4.1.3. Analogically, position on **Recalibrate** and press the button **Enter**.

6.4.2. Making recalibration

6.4.2.1. Choosing the calibration mode

After starting **Recalibrate**, the display shows the following:

Cal: 1 Cow		
Prev	OK	Next

You can choose the type of milk to be calibrated. By pressing ▼ (**Next**) you can switch between **Cal: 1**, **Cal: 2** or **Cal: 3**.

By pressing the button **OK** you are choosing the type of calibration.

6.4.2.2. Entering values for the separate sample parameters

The following menu is displayed:

Cal1 Cow		High
FAT=f.ff		
Edit	OK	Next

In this display the results, received by using the corresponding reference methods from *Appendix Methods* for **high-fat** milk analysis must be entered.

In this menu, with button ▼ (**Edit**) must be entered the values of the high fat milk sample

For example:

FAT=05.29

Cal1 Cow		High
FAT=f.ff		
-	OK	+

With buttons ▼(-),▲(+) set the needed value. With next pressing of **Enter** the cursor is moved to the next number. After needed value entering completion for FAT, press **Enter (OK)** and you are going back to the previous menu:

Cal1 Cow		High
-----------------	--	-------------

FAT=05.29		
Edit	OK	Next

With the button ▲(**Next**), choose **SNF** and in the same as above described procedure, enter the value for **SNF**. After it is finished, press “**Enter**” (OK) and you are going back to the previous menu. With button ▲ (**Next**), choose **DEN (density)** and enter the value for density; the rest of the parameters are entered in the same manner – LAC (lactose), SOL (salts), PRO (protein)

Cal1 Cow		High
PRO=f.ff		
Edit	OK	Next

If you miss to enter some of the parameters of milk, the following warning message will appear:

<p>You Must Enter Values > 00.00 Try Again</p>
--

Then you must press the button **Enter (OK)** and enter the missed parameters. After all the parameters are entered, press **Enter (OK)**.



You must enter values for all the measured milk parameters!!!

The screen for entering the results, received with the corresponding reference methods (See *Appendix Methods*) for the **low-fat** milk is displayed:

Cal1 Cow		Low
FAT=f.ff		
Edit	OK	Next

In the same way the values of milk with low fat sample are entered.



You must enter values for all the measured milk parameters!!!

In other case the calibration will not be correct.

6.4.2.3. Making recalibration with the available samples

After entering the values for the separate parameters of the sample, pressing **Enter (OK)** will display the following menu:

```
Cal: Cow
Put sample High
5 times
```

which reminds us to put 5 times the sample with high **FAT**.



The sample has to be with temperature in the boundaries 15-25°C.

Before each milk measurement stir 2-3 times the milk sample by pouring it from one vessel to another. The needed quantity is poured in the sample-holder and it is put in the recess of the analyser. Start the measurement by pressing the button **Enter**. The sample is sucked. Appears the following menu:

```
Cal: Cow
Put sample: High
5 times
Temp=....
```

After the sample is measured, appears the following menu:

```
Cow
High
N1=..... 2=.....

Cal meas=1/5
```

which reminds us to make the next measurement. Before each measurement the milk is stirred by pouring it 2-3 times from vessel to vessel. Continue the procedure till the 5th measurement.

After 5th measurement completion automatically appears the menu, which reminds us to place the **Low fat** milk sample:

Cal: Cow
Put Sampl: Low
5 times

Stir 2-3 times the milk sample before each measurement by pouring it from one vessel to another. The needed quantity is poured in the sample-holder and it is put in the recess of the analyser. Start the measurement by pressing the button **Enter**. The sample is sucked. Appears the following menu:

Make 5 times measurement of the low FAT sample.

After 5th measurement completion automatically appears the menu:

Cal: Cow
Put sample: Water
5 times

Which reminds for 5-times water measurement.

After the 5th measurement appears the menu:

Recalibrated
Power Off-On

This means that the calibration was completed successfully and the analyzer is recalibrated for cow milk, marked as “Cal: Cow”.

Switch off the power supply of the device and switch it on again.

The device is ready to work with the new calibration.

Next time when the analyser is switched on, it will be ready for work with those milk types it was just calibrated with.

If calibration with another milk type is needed, do not forget to change the calibration number for the new type of milk.

Calibration for Sheep milk will be saved as second calibration, UHT – as third. This sequence may not be followed and calibrations can be saved in whichever order is needed. Calibration can be done with different liquid dairy products using 2 representative samples.

Checking the calibration

1. Switch on the calibrated device.

2. Make sure it shows the same serial number as this already calibrated.

For checking, use the third sample with medium FAT content.

3. Measure the milk 5 times in the mode you've calibrated it.

In case that the device is not connected towards printer write down the results.

4. Ignore the first two results.

The rest three could not differ more than 0,05% FAT, 0,07% SNF, 0,7% Density one from another

7. STARTING THE DEVICE IN A SERVICE TEST/SETUP OPERATIONAL MODE. MENUS DESIGNATION

7.1. Starting the device in a service Test/Setup operational mode.

In order to start the **Setup** of the device the operator has to press the button **Enter** and without releasing it to switch on the power supply of the device, to wait for the starting identification messages and to release the button after the following message appears on the display:

**Release button
to start setup**

After releasing the button on the display is shown:

Setup Menu

Followed by possible to be entered by the operator menus:

**Special modes
Corrections
Settings**

**Tests
Exit**

You may move in the menus by using buttons “**up**” ▲ and “**down**” ▼.
If by pressing the button **Enter** you choose a menu, each menu offers new points/submenus. When **Exit** is chosen the device leaves the **Setup** mode and returns to normal work.



Due to the continuous improvements made in the milk analyser or due to the type of the ordered product, it is possible some of the options in the device to be not active. In this case, if you try to enter the corresponding menu, the following message will appear: **Not available option.**

7.2. Menus Function:

7.2.1. Special modes.

Serve for choosing special (technological) working modes. After starting it the following appears on the display:

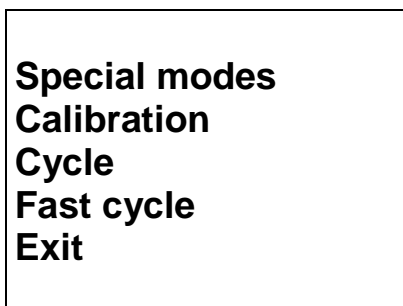

A rectangular box containing the following text:

```
Special modes
Calibration
Cycle
Fast cycle
Exit
```

This mode is normally used in production conditions.

7.2.1.2. Calibration mode

In mode **Calibration** the analyzer is ready to make measurement and to send the received results towards the technological milk analyzers calibration system. For this purpose you need personal computer type IBM PC, company's calibration system LSC.EXE and methods for calibration of milk analyzers (see the corresponding documents). To start measurement in this mode, the operator has to put a sample-holder containing milk sample in the recess of the analyzer and to press the button **Enter**.

7.2.1.2. Cycle mode / Fast Cycle mode

Mode **Cycle** serves for training the analyzers. When you start this mode, the analyzer, without additional commands, sucks the sample, makes the measurement, pours the sample out in the sample-holder and displays the received results cyclically.

Note:

This mode is normally used in production conditions. It is recommended the customer to calibrate the device using the embedded function Recalibrate (i.e autonomous, without computer)

7.2.2. Corrections

Serves for entering corrections in the measured data. Detailed description in point 6.3.2 and 6.3.3.

7.2.3. Settings.

Serve for assigning different working parameters (modes).

7.2.3.1. Net number.

Serves for assigning the device network number when connecting it in the production network. The possible numbers are from 0 to 15 including.

After starting this function the display shows the following:

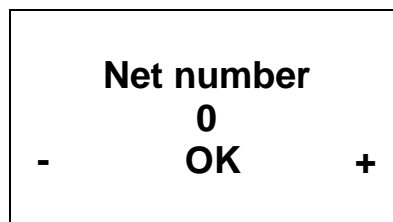

By using the button “up”▲ the operator has the possibility to increase the number, showing the channel’s number, and by button “down”▼, to decrease it. Pressing the button **Enter** saves the chosen channel and exits the function.



When connected in the production network each device has to have a unique number.

7.2.3.2. Recalibrate.

Serves for changing definite calibration. Methods are described in point 6.4.

7.2.3.3. Save/Rest Cal.

Through this menu you may save the new calibration in the device or to restore the old one (factory) calibration. This is necessary in case that you’ve calibrated the device for cow milk, but after that the device is not measuring correctly and you decide to restore the factory calibration settings. Position the cursor across “**Restore calibration**” and press “**Enter**”

Possibilities:

Save calibration – saves the chosen calibration in an internal buffer.

Restore calibration – restores the chosen calibration from the internal buffer.

The procedure **Save/Restore** is done for each calibration separately.

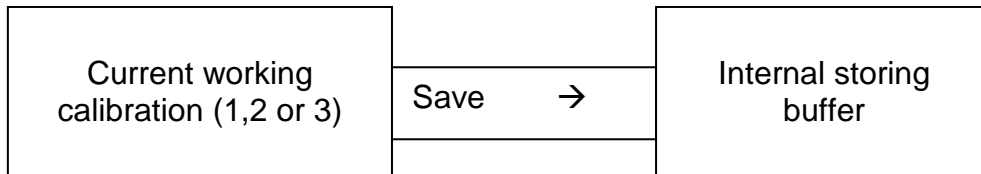

Current calibration content is not changed, the analyzer continues using it, but there is a reserve copy in an internal buffer.

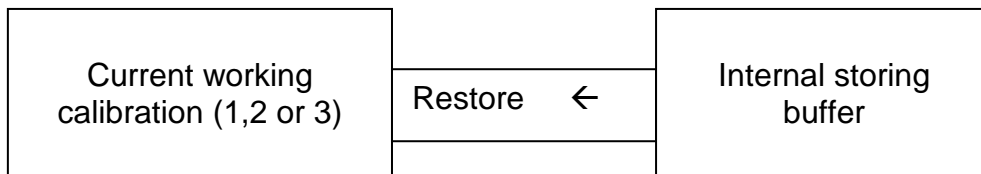

The current calibration is replaced with the calibration from the internal buffer and the analyzer starts working with it. The content of the internal buffer is not changed.



If after recalibration “Save calibration” is pressed the new calibration settings will be saved over the factory settings. After that is impossible to restore the factory settings of the calibration. Save the newly made calibration only if you are sure about its correctness.

7.2.3.4. Settings Page 2.

After this menu is started the display shows the following:

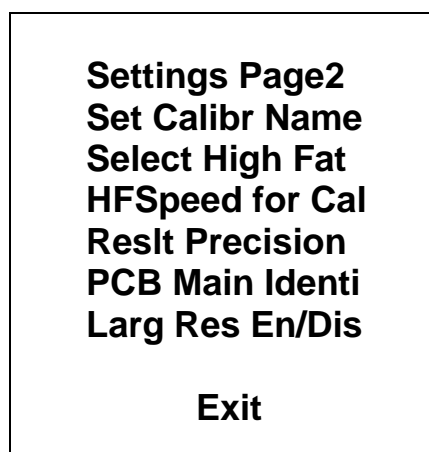

Now there is a possibility one of the following options to be set:

7.2.3.4.1. Larg Res En/Dis.

The format of the measurement data send towards the computer is set.

If the option **Large Disable**, is chosen, then only the main results are send to the computer – Fat, SNF, Density, Lac, Proteins, Added Water, sample temperature, device serial number and calibration number.

If the option **Enable**, is chosen, except the above mentioned parameters also data for Salts, Freezing Point, pH, Conductivity will be send to the computer. In this case is necessary the software in the computer to be conformable to the format of the sent data. After starting the menu, the display shows (for example):

Large Results
No

No OK Yes

7.2.3.4.2. Select High Fat

If the analyzer has embedded function for measurement of high fat products, by this menu the calibration, with which this measurement to be made is chosen. What is seen when this option is turned on is an obvious slowdown of the sample's suction speed.

7.2.3.4.3. HFSpeed for Cal

If the analyzer has embedded function for measurement of high fat products, and a new calibration for high fat measurement is needed, before starting the new calibration the operator has to start this menu. What is seen when this option is turned on is an obvious slowdown of the sample's suction speed during calibration.

Please, pay attention to the fact that switching off the power supply cancels this command action.

7.2.3.4.4. Reslt Precision

Serves for setting the precision of the measured results shown on the display. It is set separately for every parameter, the precision could be 0.01 (standard) or 0.1.

7.2.3.4.5. PCB Main Identi

Gives information about the type and the version of the analyser (LS Identity).

7.2.3.4.6. Set Calibr Name.

Sets the names of the separate calibrations. The name could be chosen from the group of predefined calibrations names or to edit a new one. When editing the new name there is a possibility all ASCII codes to be used, as letters (caps and normal), numbers and punctuation marks and popular symbols. The calibration name consists of 8 symbols.

Example:

When it is suitable to us this possibility of the analyser? For example if you have a device factory calibrated for Cow milk, Sheep Milk and UHT milk, but you need often to measure camel milk. Using the methods, explained in details in Appendix Methods you may make a new calibration without need to send the analyser back to the producer for calibration. Using this procedure you may make calibrations for most often analysed milk and to write down the exact calibration name, which will be shown on the display and printed on the printer.

After starting this menu the display shows:

Cal:1 Cow

\Prev OK Next

There are the following possibilities:

With button **OK** – to start editing the name of the chosen calibration.

With button **Prev** – to choose the previous calibration, chosen for setting the calibration name.

With button **Next** – to choose the next calibration name for editing.

If the operator has chosen and confirmed calibration for change of the name, the display shows (example):

Cal:Cow

PreDef Exit Edit

There are the following possibilities:

With button **PreDef** – to choose a calibration name from the list of preliminary given names.

With button **Exit** – to leave the menu.

With button **Edit** – to edit the new calibration name.

If a name from the preliminary given names list is chosen, the display shows:

Cal1: Cow
New Cow

Exit Yes Next

There are the following possibilities:

With button **Exit** – to leave the menu.

With button **Yes** – to confirm the chosen from the list calibration name. Now the program returns to the beginning of the menu for setting calibration names.

With button **Next** – to show the next calibration name from the list.

If it is decided a new calibration name to be edited, the display shows:

Cal1: Cow
New Cow

Prev Set Next

There are the following possibilities:

With button **Prev** – to display the previous ASCII symbol.

With button **Set** – to confirm the ASCII symbol, shown on the display and passes to editing the next symbol from the calibration name.

With button **Next** – to show the next ASCII symbol.

The editing finishes by entering the eighth symbol from the name of the calibration.

7.2.3.5. Set Base Frpnt.

Serves for editing the Basic Freezing Point. It is used by the customer according the Appendix for calculation of the added water and determination of the Freezing point of the sample.

7.2.4. Tests.

Start different tests. Possibilities:

7.2.4.1. Test pump.

Starts pump's test. The number of the completed suction/display cycles is indicated.

7.2.4.2. Ultrasound.

Test for the ultrasonic system. Used in production conditions.

7.2.4.3. Set Amplitude.

Serves for ultrasound amplitude adjustment. It is used under production conditions or by the customer (after sensor change) according the instructions in the document SetCell.pdf.

7.2.4.4. RS232 COMPort

7.2.5. pH meter & Co meter



Please, use this menu only after reading the above pointed document SetCell.pdf

7.2.6. Exit

By pressing the button you may leave the program and pass towards another menu.

7.2.7. Milk analysers' setup menu structure

Analyzer Setup

Special
modes

Calibration
Cycle

Corrections

Measurement
Temperature

Settings

Net number
Recalibrate

Save Calibr
Restore Calibr
Settings Page2

Set Calibr Name
Select High Fat
HFSpeed for Cal
Reslt Precision
PCB Main Identi

Tests

Set Base FrPnt

Test pump
Ultrasound
Set Amplitude

8. ADDITIONAL POSSIBILITIES OF THE ANALYZER

8.1. Connecting to 12 V DC power supply.

If there is a need the analyzer to work on place without electrical supply available, then it could be powered by car battery or other 12 V DC external power supply. Use the 12 V power supply cable, supplied with the analyser.

8.2. Connecting to IBM PC

The milk analyser can be connected to IBM PC using the RS232 interface cable. In order to make the connection: switch off both milk analyser and PC. Connect the RS 232 cable towards Serial interface and towards the computer. Turn on both milk analyser and PC. Now the milk analyser is ready to communicate with IBM PC. This is enough for starting the program for collection and archive of the measurement results. For more detailed information regarding milk collection data program see the file resLS.

8.3. Connecting a printer (option).

In order to print out the measurement results, a serial printer could be connected to the device – for example ESC/POS Serial printer, production of Datecs or Seiko. The interface connector for the printer is on the rear panel of the device – “Serial printer output”. The printer (if it is Datecs), should be connected to the “12 V printer output” on the device rear panel. Connect it via cables, delivered by the company-producer. If the printer is connected directly to the electrical network, then the analyzer and the printer should be connected to one and the same electrical phase.

Communication parameters: 9600 bps, No parity, 8 bits, 1 stop bit. It's one-way communication (uses one line) – the analyzer only sends and the printer only accepts data.

8.4. Measuring high fat samples (option).

The standard device measures samples up to 25% fat.

On customer's request, the device could be produced with possibility to measure samples up to 50% fat. The customer can choose which calibration to have this possibility and which not, as well as during the process of exploitation to change the measuring mode i.e. to pass from measuring normal fat percentage towards high and vice versa.

What the operator sees during these passes is the difference in the speed of sucking the sample. For that purpose, the high-fat sample has to be preliminary heated up to 30C +- 3C.

To choose the mode, follow the sequence below:

Setup->Settings->Settings
Page2->Option
Select->SelPumpSpeed->Speed for Cal x

After which the display shows:

```
Calibr x
Pump Speed
Normal OK HiFat
```

By pressing the correspondent buttons the operator can choose the type of measurement and to exit the menu.

When changing the type of measurement on a calibration is necessary a new calibration of the device on the new speed to be done. When calibrating measuring high fat sample, before starting the calibration procedure, the operator has to choose from the menu:

Setup->Settings->Settings
Page2->Option
Select->SelPumpSpeed-> HFSpeed for Cal

By which the device passes in a mode of measuring high fat samples. This calibration mode is active till the power supply of the device is switched off i.e. it has to be always set if the device will be calibrated for high fat measurement.

8.5. Embedded real time clock (option).

On customer's request, a real time clock could be embedded in the device, showing astronomical time and date. The clock is powered by battery, so it is independent on power supply of the device. The advantage of this option is that on the print out with the measurement results are shown also the exact time, when the measurement is made, for example:

```
Time: 18:14:33
Date: 22:03:2007
Lactoscan MCC30
Serial Number:0002
Calibr 1 Camel
Results:
Fat.....00.00%
SNF.....00.00%
Lactose.....00.00%
Solids.....00.00%
Protein.....00.00%
Temp. Sample...21.0°C
```

The embedded clock is controlled by the device's Setup, from the main menu Accessories, submenu RT Clock. When chosen, the display shows the following:



Using these menus, the operator has the possibility to show on the display the current time and date, and if necessary – to adjust them. The time is shown in the format:

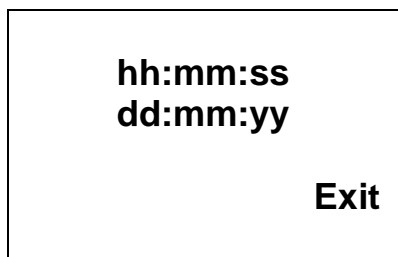

where:

- hh - the current hour
- mm - current minutes
- ss - current seconds
- dd - current day
- mm - current month
- yy - current year

APPENDICES**APPENDIX 1: PREPARATION OF SAMPLES FOR MILKANALYSERS' CALIBRATION**

For calibration are needed samples of cow milk with the following parameters:

		Low Fat	High Fat	Middle
1	Cow	2,2%	5,2%	3,6%

For the calibration are needed:

1. Distilled water
2. Min. 3 milk samples with known values for fat, SNF, protein, density, lactose, salts.

Calibration samples have to be with low, middle and high values of the analyzed components. Samples have to be representative for given milk type. Volume of the sample has to be enough for making min 5 measurements for each sample – not less than 1,00 l. Changes in the analyzed parameters in the samples have, if possible, to cover the whole measuring range – i.e. used samples to be with low, middle and high content of the analyzed components.

Methods of milk samples preparation for calibration.

For milk sample with middle value of the analysed components we recommend to use milk taken from not less than 10 animals from most common in the region breed.

Sample with low and high value are prepared on the following way:

1. Pour the fresh milk with FAT at about 3.7% in a separating funnel.
2. Leave the funnel with the milk in refrigerator for 12 hours at temperature +5-+8 ° C.
3. Draw the substratum of the separated milk in a vessel, mix it well, pour it and heat it in water-bath up to 20°C.
4. Pour the upper layer in another vessel.
5. Determine the concentration of the measured components (FAT, protein, SNF, density, lactose, solids) by using certified methods.



The analyser's accuracy depends only on the correctness of the chemical analysis of the components in the samples and the normal acidity during calibration!

It is recommended the first cow milk sample with low fat content to be with the following parameters:

2-2,3% FAT; 8.7-9% SNF; 3,3-3,5 % Protein; 4,8-4,9% Lactose; 0,75 Salts; 1030-1033 kg/m³ Density.

The second cow milk sample with high fat content to be with the following parameters:

5-5,3% FAT; 8.4-8,79% SNF; 3,1-3,2% Protein; 4,6-4,7% Lactose; 0,7 Salts; 1028-1029 kg/m³ Density.

If, after milk's separation you do not obtain samples in the requested range, then, by adding milk with high fat value into the low fat milk sample you can obtain necessary value-2,3%

Analogous to this, by adding low fat milk sample into a milk sample with high fat value you may receive 5,3%

Samples with medium values are received by mixing low fat and high fat samples in necessary proportion.

If there is a need of longer sample storing they have to be preserved; the most commonly used preservative is potassium dichromate (K₂Cr₂O₇) - 1 g for 1 000 ml.

When using samples, stored shortly, preliminary pour the sample from one vessel to another in order to distribute the milk components evenly paying attention not to form foam in the sample.

When the samples are stored for a longer period it is recommended to warm it up to 35-45 °C, and the vessel to be shaken carefully. In case that there is a cream stuck on the vessel's surfaces – remove it. The sample is poured from vessel to vessel several times and is cooled down (advisable to 20 °C /.



If there is separated liquefied fat or white particles with irregular form on the vessel's walls reliable results could not be received.

Because it is very difficult both lactose and salts to be measured but they are substantial and influence in great extend when determine added water. That's why it is better both lactose and salts to be calculated by using SNF results. The milk must be for sure without added water.

If you are unable to make the analysis of milk in certified methods in a pinch you can use the following formulas:



DETERMINATION OF THE BASIC PARAMETERS IN THE MILK SAMPLE BY USING FORMULAS IS NOT AS PRECISE AS USING THE ARBITRARY METHODS, BUT IS SUITABLE FOR USAGE IN FIELD WORK.

1. Determination some of the parameters by formulas

There is dependence between the different parameters in milk and its density, which may be expressed with mathematical equation. On this base different formula, tested and confirmed by the classical laboratory methods for analysis, are developed. We recommend the following:

2. SNF determination.

For determination of SNF the correlation dependence exists between the milk's density, fat and SNF in the milk. When the density and the fat are known, the SNF can be calculated.

There are several formulas with different applicability.

A/ When the Total Solids and fat are known

SNF is calculated by subtracting the fat percentage from the Total solids.

$$SNF = \text{Total Solids} - F (\%)$$

Where

Total Solids in (%),

F – fat content in (%),

This formula is used for determination of SNF in whey, buttermilk, and cream.

B/ Known quantity of fat and density (most commonly used method when maximum accuracy is needed).

We recommend the following formula:

$$SNF = \frac{0,075 * F\% + 100 - 100 / \text{density}}{0,378}$$

This is a universal formula and actual for milk of almost all kind of cows and sheep all over the world.

3. Determination of lactose content

We recommend the following formulas:

A/ for cow milk

$$\text{Lact.} = SNF * 0,55 (\%)$$

Where

SNF – content of SNF in percentages (%),

0,55 – constant coefficient.

B/ for sheep milk

$$\text{Lact.} = SNF * 0,45 (\%)$$

Where

SNF –solids-non-fat content in percentages (%),
0,45 – constant coefficient.



This is an actual coefficient for sheep breeds on the territory of the Balkan Peninsula.

4. Determination of salts content

We recommend using the following formulas:

A/ for cow milk

$$\text{Salts} = \text{SNF} * 0,083 (\%)$$

Where

SNF – solids-non-fat content in percentages (%),
0,083 – constant coefficient.

B/ for sheep milk

$$\text{Salts} = \text{SNF} * 0,075 (\%)$$

Where

SNF – solids-non-fat content n percentages (%),
0,075 – constant coefficient.



This is an actual coefficient for sheep breeds on the territory of the Balkan Peninsula.

5. Determination of total proteins content

We recommend using the following formulas:

A/ for cow milk

$$\text{Protein} = \text{SNF} * 0,367 (\%)$$

Where

SNF - solids-non-fat content in percentages (%),
0,367 – constant coefficient.

B/ for sheep milk

$$\text{Protein} = \text{SNF} * 0,475 (\%)$$

Where

SNF – solids-non-fat content in percentages (%),

0,475 - constant coefficient.



This is an actual coefficient for sheep breeds on the territory of the Balkan Peninsula.

APPENDIX 2 FREEZING POINT DETERMINATION

1. Methods for determination.

The milk analyzer determines the freezing point of each sample and the quantity of added water. The milk analyser does not measure the freezing point, but calculates it from the components it depends on. The basic components in the milk are water, solids, lactose, FAT, proteins, minerals (salts) and acids. The freezing point depends only on the diluted in the milk components and quantity of the solvent (in the milk it is water). The ultrasonic technology allows direct measurement of FAT, proteins, lactose + salts (the soluble components, only influencing the freezing point), and the quantity of the solvent in % is determined by $100\% - \text{total solids \%}$, $\text{total solids} = \text{lactose \%} + \text{FAT \%} + \text{proteins \%} + \text{salts \%} + \text{acids \%}$.

Without understanding the meaning of the freezing point – determined or shown from the milk analyzer added water result easily may lead to a mistake for the value of this parameter.

2. The basic freezing point.

Milk freezes at lower temperature than water. The average freezing point of the raw milk in the most regions is at about $-0,540^{\circ}\text{C}$. The average reading for your region is called “basic” freezing point.

The freezing point of milk is a “physiological constant”. This does not mean that it will not vary. In fact feed, breed, season, time of lactation, climate, whether the sample is taken at the beginning, middle or end of lactation – all these factors will have an effect on the freezing point of the individual sample. This means that there is an average value of all these numbers. The more samples used in obtaining this average, the more reliable it is as a base. Or the basic freezing point is an average of freezing points of milk, taken from many cows. When a laboratory checks a producer, it is only comparing the average of the producer’s cows against a larger area average.

The Health authorities establish the basic freezing point or agriculture departments in some regions, sometimes by universities, separate dairy producers, or their associations. Frequently, tolerances have been established on top of a basic freezing point to allow some variations in the milk as well as device or operator variations.

Without mentioning the basic freezing point, the Association of Official Analytical Chemists now recommends an upper limit freezing point at $-0,525^{\circ}\text{C}$ (2,326 standard deviations above the most recently determined North American average of $-0,5404^{\circ}\text{C}$), below which there will be at 95%

confidence that will show 99% of all freezing point determinations on unwatered milk:

“if the freezing point is $-0,525^{\circ}\text{C}$ or below, milk may be presumed to be free of water or may be confirmed as water free by tests, specified below. If the freezing point is above $-0,525^{\circ}\text{C}$, milk will be designated as “presumptive added water” and will be confirmed as added water or added water free by tests specified below. Evaluate extreme daily fluctuations in the freezing point of herd, pooled herd, or processed milk for presence of added water”.

“Presumed added water”, as described above, must be “confirmed” by means of tests on authentic milk samples obtained as specified in the AOAC METHODS.

After determination the freezing point of your sample via the milk analyzer, the added water is calculated using the following formula:

$$\text{AddedWater} = \frac{\text{FrPoint}_{\text{Base}} - \text{FrPoint}_{\text{Calc}}}{\text{FrPoint}_{\text{Base}}} * 100[\%]$$

Where:

FrPointBase is the basic freezing point

FrPointCalc is measured freezing point

Note:

If the freezing point is not correctly determined, the result for the added water is not valid. In this case results for FrPoint and AddWater are not shown on the display and on the printout from the printer. If the density of the measured sample is 0, the result for AddWater is not valid and is also not shown on the display and the printouts.

Sample:

First variant

If you’ve entered for milk analyzer basic freezing point -0.520°C (according article 5.9 of the EU Milk Hygiene Directive 92/46/EEC), measured freezing point -0.540°C , using the above pointed formula you’ll receive $-3,8\%$. Because it is not possible the added water to be negative value, the milk analyzer indicates 0% added water. The reason for this is the tolerance in the basic freezing point, reasons for which are described below.

If in the same milk we add 3,8% water, and the basic freezing point is the same, the milk analyzer will measure freezing point -0.520°C , and will indicate again 0% added water.

Second variant

If you've entered for the device basic freezing point -0.540°C , measured freezing point -0.540°C , the milk analyzer will indicate 0%. When you add 3,8% water, the device will indicate 3,8%-added water.

From the above mentioned follows that it is very important to enter correct basic freezing point in the device.

The device's results for added water may give information about doubt of added water in the milk and the exact value of this added water may be determined after a "cowshed sample" is taken and the result for the freezing point, measured by the milk analyzer of the "cowshed sample" is entered as basic freezing point in the formula for calculation of added water.

Then the result from this formula will give us the absolute value of the added water for the corresponding milk supplier.

APPENDIX 3 PH MEASURING

1. General information

PH probe is a unit, measuring the solution acidity or alkalinity degree. It is measured on scale of 0 to 14. The term pH is derived from "p", the mathematical symbol for the negative logarithm, and "H", the chemical symbol of Hydrogen. The formal definition of pH is the negative logarithm of the Hydrogen ion activity.

2. pH Electrode

For pH measurement the milk analyzer needs a combination electrode, compatible with most pH electrodes that have BNC connectors and zero potential (the pH where the mill volt output of the electrode equals 0) near 7 pH.

2.1. Electrode part

The electrode is the most important part of the pH measurement. The electrode glass membrane is fragile and must be handled with care. To protect the glass membrane and to maintain activation, a protective rubber cap containing a suitable storage solution covers the glass membrane.

2.2. Electrode care & Electrode maintenance

pH Electrodes are susceptible to dirt and contamination and need to be clean regularly depending on the extent and condition of use. At no time should one touch or rub the glass bulb as this causes the build-up of electrostatic charge.

2.3. Storage

For best results, always keep the pH bulb wet. An optimal storage solution for combination electrode is pH 4 buffer with 225 grams of KCl per liter. Table salt, NaCl, can be used if KCl is not really available. Other pH buffers or tap water are also acceptable storage media, but avoid storage in de-ionized water. The protective rubber cap filled with the buffer solution provides ideal storage for long periods.

2.4. After Use

After measurement is completed, follow the sequence below for storage.

- Wash the electrode and reference junction in de-ionized water.
- Close the refilling hole by returning its rubber sleeve or stopper cap. (Necessary for only refillable electrode).
- Store the electrode as mentioned above (see section Storage).

2.5. Electrolyte Replacement (for refillable electrode only).

The reference electrolyte needs to be refilled when the electrode has been used for a long period, or when the internal electrolyte has dried up. To accomplish this, follow the procedure described below.

- Remove the protective rubber cap or sleeve;
- Remove the protective rubber sleeve to expose the filling port of the electrode;
- Remove the old reference electrolyte with a syringe;
- Fill the new reference electrolyte.

2.6. New electrolyte preparation:

- Open the KCl container;
- Add in de-ionized water until it reaches the level of 20 ml;
- Close the container and shake it to dissolve the KCl;
- Add in fresh electrolyte until it reaches the level of the refilling port. The reference electrolyte used should be 3M(Mol) KCl;
- Replace the rubber sleeve.

2.7. Re-use the electrode.

- Rinse the liquid junction with de-ionized water.



If these steps fail to restore normal electrode response, you may attempt to rejuvenate it (See: Electrode Rejuvenation).

2.8. Electrode cleaning

Electrodes which are mechanically intact can often be restored to normal performance by one or combination of the following procedures.

- Salt deposits:

Dissolve the deposit by immersing the electrode in tap water for ten to fifteen minutes. Then thoroughly rinse with de-ionized water. Wash the electrode pH bulb in a little detergent and water. Rinse electrode tip in with de-ionized water.

- Oil/Grease films:

Wash electrode pH bulb in a little detergent and water. Rinse electrode tip with de-ionized water.

- Clogged Reference Junction:

pH electrodes have junction, which allows the internal fill solution of the measuring electrode to leak out into the solution being measured. The

junction can become clogged by contamination in the solution. If a clogged junction is suspected it is best to clear the junction.

Heat up the diluted KCl solution to 60-80°C. Place the sensing part of the pH electrode into the heated KCl solution for approximately 10 minutes. Allow the electrode to cool while immersed in some unheated KCl solution.

- Protein Deposits

Prepare 1% pepsin solution in 0.1 M HCl. Allow the electrode to stand in this solution for five to ten minutes. Rinse the electrode with de-ionized water.

2.9. Electrode activation

Generally, if the procedure of storage and maintenance had been closely followed, the electrode can

be used immediately. However, should the electrode response become sluggish, it may be possible that the bulb has dehydrated.

The bulb can be dehydrated by immersing the electrode in an ideal storage solution (e.g. buffer pH 4 solution) for 1-2 hours. If this fails, the electrode may require re-activation. If the above procedure does not reactivate the electrode to acceptable status, try rejuvenation the electrode by following the procedure outlined below.

2.10. Rejuvenation Procedure

Dip and stir the electrode in freon or alcohol for 5 minutes.

Leave the electrode in tap water for 15 minutes.

Dip and stir the electrode in concentrated acid (HCl, H₂S₄) for 5 minutes.

Leave the electrode in tap water for 15 minutes.

Dip and stir in strong base (NaOH) for 5 minutes.

Leave the electrode in tap water for 15 minutes.

Test with standard calibration solution.

Finally, test with standard calibration buffer solution to see if the electrode yields acceptable results. You may repeat again for better response (maximum 3 times). If the response does not improve, then the electrode has completed its useful life. Replace with a new electrode.

2.11. Electrode Lifespan

pH electrodes have a finite lifespan due to their inherent properties. How long a pH electrode will last will depend on how it is cared and the solution it is used to measure. Even if an electrode is not used it still ages. Electrode demise can usually be characterized by a sluggish response, erratic readings or a reading, which will not change. When this occurs an electrode can no longer be calibrated. pH electrodes are fragile and have a limited lifespan. How long an electrode will last is determined by how well is maintained and the pH application. The harsher the system, the shorter the lifespan. For this

reason it is always a good idea to have a back-up electrode on hand to avoid any system down time.

3. Buffer Solutions

Buffers are solutions that have constant pH values and the ability to resist changes in that pH level. They are used to calibrate pH measurement system.

PH buffer solution description (Pharmacopoeia standard)

Use only this types standard buffers for calibration!

Description	pH 7.00±0,01/20°C	pH 4.00±0,01/20°C
Composition	Potassium dihydrogen phosphate, Di-sodium hydrogen phosphate	Borax, Sodium hydroxide solution
Temperature parameters	10°C - 7.06 25°C - 6.99 20°C - 7.00 30°C - 6.98 40°C - 6.95 50°C - 6.91	10°C - 4.00 25°C - 4.00 20°C - 4.00 30°C - 4.00 40°C - 4.00 50°C - 4.05

4. pH Electrode Calibration

pH Electrodes are like batteries; they run down with time and use. As an electrode ages, its glass changes resistance. For this reason, electrodes need to be calibrated on a regular basis. Calibration in pH buffer solution corrects for this change.

Calibration is an important part of electrode maintenance. This assures not only that the electrode is behaving properly but that the system is operating correctly.

Usually pH meters require calibration at 3 specific pH values. One calibration is usually performed at pH 7, second and third are typically performed at pH 4 and pH 10.



It is best to select a buffer as close as possible to the actual pH value of the sample to be measured. Use standard calibration buffers that the temperature and the sample solution are the same.

Use the operation manual for the corresponding pH meter.

For Sensorex pH electrodes, originally supplied with Lactoscan read the following information:

Temperature compensations

The output of pH electrodes varies with temperature in manner, predicted by theory. When needed, Sensorex can supply electrode holders with build-in automatic temperature compensators. The need of automatic compensation depends on the temperature variation, the pH value being measured. At pH of about 7 there is no error due to temperature and, of course, at a constant temperature there is no error. As shown in the following table, the pH error due to temperature is a function of both the temperature and the pH value being measured. At a pH of about 7 there is no error due to temperature and, of course, at a constant temperature there is no error. The more the temperature changes from the ambient calibration temperature and the more the pH departs from 7 the greater is the pH error.

pH temperature error table

°C	pH										
	2	3	4	5	6	7	8	9	10	11	12
5	.30	.24	.18	.12	.06	0	.06	.12	.18	.24	.30
15	.15	.12	.09	.06	.03	0	.03	.06	.09	.12	.15
25	0	0	0	0	0	0	0	0	0		0
35	.15	.12	.09	.06	.03	0	.03	.06	.09	.12	.15
45	.30	.24	.18	.12	.06	0	.06	.12	.18	.24	.30
55	.45	.36	.27	.18	.09	0	.09	.18	.27	.36	.45
65	.60	.48	.36	.24	.12	0	.12	.24	.36	.48	.60
75	.75	.60	.45	.30	.15	0	.15	.30	.45	.60	.75
85	.90	.72	.54	.36	.18	0	.18	.36	.54	.72	.90

0 pH Error Range Less than .1 pH Error Range

5. PH helpful hints

For greatest accuracy in pH measurement, follow these guidelines:

Use the same technique to measure samples, which was used for calibration.

Be consistent with stirring rates, times and conditions.

Calibrate with buffers, which are close in temperature to that of the sample.

Calibrate the pH electrode regularly, e.g. once an hour for accuracy to within 0.01 pH, or once a day for accuracy to within 0.1 pH.

Use fresh buffers for calibrations. Avoid contamination of the stock buffer solution and do not use it beyond the expiry date.

Keep all connections dry.

Immerse the electrode far enough into the solution to insure the reference junction is below the surface.

Allow adequate time for the electrode to stabilize in standards and samples before taking a reading.

Clean the electrode periodically. Allow more time for aged electrodes.

Do not use the pH electrode in solutions of fluoride ion at low pH. This will etch the glass membrane.

Sulphide vapors can permeate the electrode wick and contaminate the reference element. Minimize contact in such environments and change the reference electrolyte frequently.

1. Preparation for pH measurement

When the analyzer is with pH measuring option, it is received from the customer with pH probe packed separately and there's a stopper on its place. If you need to measure pH follow the procedure below:

1. Loosen the nut anti-clockwise.
2. pull up the stopper
3. Carefully place the pH probe paying attention not to remove the sealing O-ring.
 1. Place the probe with the nut in the hole and tighten it.

Fig. 7 Placing the stopper



It is very important to close the nut tightly, paying attention not to allow air to enter the system.

Fig. 8 Placing the probe





If you are working with the analyser regularly (each day) do not remove the probe after work..



If you 'll not use the analyser more than 2 days, you must take out the probe and to place the stopper back.

The pH probe must be stored separately as per the instructions of point 2.3 Appendix 3.

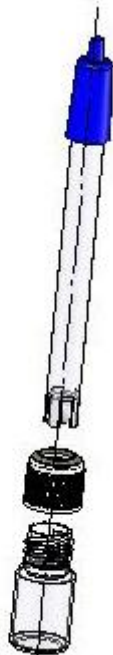

7. PH measuring.

Measuring pH is an additional feature of the analyser and is optional.

Remove the protective rubber cap of the pH electrode. Take care to handle it appropriate in order not to be damaged. Use de-ionized or distilled water to rinse the electrode before usage. Fill in the sample holder with milk, put it in the recess of the analyser and dip the pH electrode into the milk sample, ensuring complete dip of the electrode in the sample. Stir gently for homogenization of the sample.

Measuring can be done in two modes:

Off line by starting the menu **pH & Co Meter | Measuring**, when the analyser works only as a pH meter.

On line automatic pH measuring, when measuring the rest of the sample's parameters.



When starting work with pH meter first connect the probe/sensor, and then the power supply of the device.

Having in mind the characteristics of the process of pH measuring it is necessary to dip the pH probe in the sample and then to press the button Enter.

After starting the menu **pH & Co Meter** the following message appears on the display:

```
pH Calibration
pH Measuring
pH En/Disable
pH U Display
-----
pH Test
Co Meter Calibr
Co Meter Test
Co Meter En/Dis
-----
Exit
```

8.pH Calibration.

Fig. 9 Calibration buffers



Take out the sensor. You may not place the nut, because the analyzer do not sucks during calibration.

Serve for pH meter's calibration. For this purpose 2 sample buffers are used, shown on the display as **Low buffer** (for example 3.00 pH) and **High buffer** (for example 7.00 pH). Follow the procedure:



Please, use this procedure only in case that you have enough quantity calibration buffers, as they could not be used second time.

If you have no enough buffers, then place the pH probe in the vessels near the analyser.

1. Start the **Calibration** menu.
2. Put the probe in the **Low buffer**.
3. Using the analyzer's buttons enter the exact buffer value. The following is shown on the display:

pH Calibr
Put Izopot buff
Buf=xx.xxx

4. The operator has to enter the buffer's value, when the probe is in its isopotential point and to press the button Enter.

After that the display shows:

**pH Calibr
Put Izopot buff
Buf=xx.xxx
V=x.xxxV Set**

Where **x.xxxxV** is the measured in the probe voltage.

1. Press the button **Set** when the readings stop moving. The analyzer automatically takes out the calibration liquid and the display shows the following:

**Put filled with
Water glass
And Enter press
To continue**

2. The operator has to place a glass filled with distilled water and to press Enter, in order to clean the probe from previously used calibration liquid. After the cleaning the analyzer is ready to start working with the next calibration liquid.
3. Repeat the procedure with the **Next buffer**. The following message appears on the display:

pH Calibr OK

Which shows that the calibration procedure was completed successfully. The calibrated device is ready for making measurements.

8. The device automatically passes in mode pH measuring.

9. Check the correctness of the calibration by measuring buffer solution 7.00.

9. pH Measuring.

After starting this menu the measurement is done in mode off line, i.e. the analyser works only as a pH meter. The operator has to dip the probe in the sample and on the display the following is shown:

pH measuring
x.xxxV
y.yy pH
Exit

Where:

x.xxx – measured by the probe voltage

y.yy – measured probe's pH

By pressing the button **Exit**, the operator may exit the program and to pass towards another menu.

10. pH En/Disable

Serves for enabling/disabling the pH measuring during normal work of the analyser - On line. After starting it the display shows:

pH Measuring
XXX
No OK Yes

Where:

XXX is the current situation of the working mode. By pressing the buttons below the corresponding inscriptions it could be changed, as **Yes** – means that during normal work of the analyser – measuring the rest of the parameters, pH will also be measured. If **No** is chosen, then pH is not measured.

11. pH U Display

Serves for allowing/forbidding the value of the pH probe voltage during pH parameter measuring. After starting it the display shows:

PHUDisplay
XXX
No OK Yes

Where **XXX** is the current state of the displaying mode. By pressing the buttons below the inscriptions it could be changed, as **Yes** – means that during pH measuring the voltage of the pH probe will be shown.

If **No** is chosen, it will not be shown. It refers to both of the measuring modes.

12. pH test

serves for testing the measuring system in production mode.

APPENDIX 4 CONDUCTIVITY MEASURING

1. Method of determination.

Conductivity (or Electrolytic Conductivity) is defined as the ability of a substance to conduct electrical current. It is the reciprocal of the resistance.

In a healthy animal*, the mean value of electric conductivity is:

Milk type	Conductivity values
Cow milk	between 4 to 6 mS/cm (18°C);
Sheep milk	between 3 to 5 mS/cm (18°C);
Buffalo	between 2,5 to 5 mS/cm (18°C);

*These values depend on the geographical region, the breed and on other factors.

Milk conductivity changes on the concentration of ions in the milk:

Added water, sugar, proteins, insoluble solids	Decrease the ion's concentration. Milk conductivity decreases.
Added salts	Increase the ion's concentration. Milk conductivity increases. Increase the ion's concentration. Milk conductivity increases. Often the milk is falsified by adding salt: towards milk with good characteristics: fat 4%, SNF 8,8, conductivity 4,5 are added salt and water. Then the results are changed to 3,2 and 8,8, conductivity 10. In other words adding water regulates the increased value of SNF and density till normal (within the boundaries/parameters) and even the fat is normal. By the values of these parameters may be determined if the sample is falsified, but the only characteristic, proving this is conductivity, which is out of boundaries nevertheless added water. But be careful, as the falsification is not the only possible reason for conductivity increasing. The other possibility is mastitis that's why we recommend using another (chemical) method for checking it.
Significantly extreme value (6,5 - 13,00	Should indicate the development of mastitis. Infections damage the tissue of the udder. This

mS/cm (18°C)	allows sodium and chlorine ions from the blood to be released into the milk. The concentration of ions in the milk is thereby raised, and it can more easily conduct an electrical current - the conductivity of the milk increases.
--------------	--

Milk conductivity can be used as tests for degree of water evaporation in condense milk production.

Milk conductivity change notifies of powder (dry) milk solution rate.

2. Conductivity measurement

Conductivity measurement is additional possibility of the analyser and is delivered on customers request/

3. Co Meter Calibr

Serves for conductivity measuring system calibration. Clean the analyzer before starting conductivity measurement. (see p. 4.1). You need a standard buffer with conductivity 5.02[mS/cm] (you may order it for delivery together with the analyser), with temperature 18°C. After starting this mode, the analyzer makes preparation for measurement and when it is ready, the following message is displayed:

**Co Meter Value
Base= 5.02**

The basic value of the buffer solution is shown. We can use buffer solution with another conductivity (from 4 to 5 mS/cm) or refer to the Note at the end of this point. The value of the used buffer must be changed or confirmed. Pressing ENTER confirms, + or – increase or decrease the value. After 3rd pressing of ENTER the following message appears on the display:

**CoMeter Calibr
Put new sample
And press Enter**

The buffers' temperature is indicated during measurement. After finishing the measurement the following message appears on the display:

**Co meter Calibr
Put new sample
And press Enter
ADC=xxxxx/1**

Where xxxx is the result from the first calibration measurement. The operator have to put a new buffer, N.B. do not use one and the same buffer more than once! Then start the next measurement. This procedure has to be repeated 5 times. At the end the following message appears on the display:

**CoCalibr-OK
xxxx xxxx xxxx
Xxxx xxxx Diff=xxxx
Power Off/On**

Now the operator has to switch off the power supply of the analyzer. After switching it on again, the analyser has to be cleaned again with water, which ends the calibration of the conductivity measurement system calibration.

Note:

Another possibility for calibration of analyzer's conductivity measurement function.

You need conductivity meter. First measure milk with normal acidity with conductivity meter and use it as sample for calibrating the analysers conductivity measurement function.

4. Co Meter Test.

Serves for testing the working mode of the milk's sample conductivity measurement system. It is used in the production conditions. After this menu is chosen, the analyser executes the procedure for sample's measurement and the display shows the data, used for obtaining the samples conductivity.

**Co Meter Test
CoADC= xxxx
Power Off - Stop**

5. Co Meter En/Dis.

Enables or disables the conductivity measurement system. The following message appears on the display:

Cond Measuring
Yes

No OK
Yes

6. Corrections in conductivity measurement

It is done by starting the menu **Corrections -> Cond measure**. You have the possibility to increase/decrease the measured conductivity value from – 1.00 till +1.00, with step 0.01. After starting this function the display shows the following:

Con Meter
-1.0<=Corr>=1.0
Co Corr=+0.00
Edit – Up/Down

The cursor is positioned below the +. By using buttons **Up/Down**, the operator has the possibility to change the value (number). By pressing the button **Enter**, the operator confirms the chosen value and moves to the next position for editing it. After the last position is edited, if the correction value is within allowed boundaries, the following is displayed: **Co Corr Saved**, which means, that the correction is entered and saved. On the contrary – it returns at the beginning and expects valid correction.

7. Conductivity calibration buffer preparation

In order a standard buffer for conductivity measuring to be prepared follow the instruction below:

1. Take the packet with the powder buffer.
2. Carefully shake the packet in order to gather the powder at the bottom.
3. Cut one end of the packet.

4. Empty its content in a measuring mug with 1 l volume, paying attention all its content to be emptied.

For standard buffer: 5,02 ms – 3,056 г

5. Add 600-700 ml distilled water, which was preliminarily deaerated in vacuum dryer or boiled and then cooled down to 20 °C.
6. Shake the mug till the powder is fully dissolved.
7. Add distilled water to the mark.

Contents:

FUNCTION.....	6
2. TECHNICAL PARAMETERS	7
2.1. WORKING MODES CHARACTERISTICS:	7
2.1.1. MEASUREMENT MODE MILK / DAIRY PRODUCT – FIRST TYPE	7
2.1.2. MEASUREMENT MODE MILK / DAIRY PRODUCT – SECOND TYPE	7
2.1.3. MEASUREMENT MODE MILK / DAIRY PRODUCT – THIRD TYPE	7
2.1.4. CLEANING.....	7
2.1.5. PRINTING	7
2.2. MEASURING RANGE:.....	8
2.3. ACCURACY:.....	8
2.4 CORRECT AMBIENT CONDITIONS:	9
2.5. DIMENSIONS:	9
2.6. CONTINUOUS WORKING TIME:.....	9
2.7 MILK SAMPLE VOLUME PER ONE MEASUREMENT:	9
FIG. 4 PERIPHERALS CONNECTION	12
3. QUALIFICATION OF RAW MILK, THERMALLY TREATED MILK, OTHER DAIRY PRODUCTS AND DERIVATIVES	15
3.1. TAKING SAMPLES AND PREPARATION FOR ANALYSIS	15
3.2. MAKING THE MEASUREMENT.....	15
3.2.1. PREPARING THE ANALYZER FOR WORKING MODE	15
3.2.2. MAKING ANALYSIS	16
3.2.3. DISPLAYING THE RESULTS	17
MODE PRINTING	18
4. CLEANING THE ANALYZER.....	19
4.1. PERIODICALLY CLEANING (RINSING) THE ANALYZER	19
4.1.1. PERIODICAL CLEANING FREQUENCY	19
4.1.2. MAKING THE RINSING	20
4.2. COMPLETE CLEANING.....	20
4.2.1. COMPLETE CLEANING FREQUENCY	20
4.2.2. CLEANING.....	21
FIG. 5 LABELS FOR THE CLEANING CHEMICALS.....	21
4.3. PERISTALTIC PUMP SERVICE.....	23
FIG.6 PERISTALTIC PUMP	23
5. POSSIBLE MALFUNCTIONS AND ERROR MESSAGES, TROUBLESHOOTING	23
6. MAKING CORRECTIONS AND RECALIBRATION OF THE DEVICE.....	26
6.1. TAKING SAMPLES AND PREPARATION OF SAMPLES FOR CHECKING THE ACCURACY OF THE MILK ANALYSER, MAKING CORRECTIONS AND RECALIBRATION	26
6.2. DETERMINATION THE TYPE OF THE DISCREPANCY:	26
6.2.1. MAKING MEASUREMENTS	26

6.2.2. ANALYSING THE MEASUREMENT RESULTS	26
6.3. MAKING CORRECTIONS	27
6.3.1. POSSIBLE CORRECTIONS, LIMITS AND CHANGING STEPS	27
6.3.2. PREPARING THE ANALYZER FOR MODE CORRECTIONS	28
6.3.3. MAKING CORRECTION	28
6.4. RECALIBRATING THE MILK ANALYSER.....	30
6.4.1. RUNNING THE ANALYSER IN MODE RECALIBRATE	30
7. STARTING THE DEVICE IN A SERVICE TEST/SETUP OPERATIONAL MODE. MENUS DESIGNATION.....	36
7.1. STARTING THE DEVICE IN A SERVICE TEST/SETUP OPERATIONAL MODE.....	36
7.2. MENUS FUNCTION:	37
7.2.1. SPECIAL MODES	37
7.2.2. CORRECTIONS	37
7.2.3. SETTINGS	38
7.2.4. TESTS.....	42
7.2.5. EXIT.....	43
7.2.6. MILK ANALYSERS' SETUP MENU STRUCTURE.....	44
8. ADDITIONAL POSSIBILITIES OF THE ANALYZER	45
8.1. CONNECTING TO 12 V DC POWER SUPPLY.....	45
8.2. CONNECTING TO IBM PC.....	45
8.3. CONNECTING A PRINTER (OPTION).....	45
8.4. MEASURING HIGH FAT SAMPLES (OPTION).....	45
8.5/ EMBEDDED REAL TIME CLOCK (OPTION)	46
APPENDICES	48
APPENDIX 2 FREEZING POINT DETERMINATION	53
1. METHODS FOR DETERMINATION	53
2. THE BASIC FREEZING POINT	53
1. GENERAL INFORMATION	56
2. PH ELECTRODE	56
2.1. ELECTRODE PART	56
2.2. ELECTRODE CARE & ELECTRODE MAINTENANCE	56
2.3. STORAGE.....	56
2.4. AFTER USE.....	56
2.5. ELECTROLYTE REPLACEMENT (FOR REFILLABLE ELECTRODE ONLY).....	57
2.6. NEW ELECTROLYTE PREPARATION:.....	57
2.7. RE-USE THE ELECTRODE.	57
2.8. ELECTRODE CLEANING.....	57
2.9. ELECTRODE ACTIVATION	58
2.10. REJUVENATION PROCEDURE	58

2.11. ELECTRODE LIFESPAN.....	58
3. BUFFER SOLUTIONS	59
4. PH ELECTRODE CALIBRATION	59
5. PH HELPFUL HINTS	60
1. PREPARATION FOR PH MEASUREMENT	61
FIG. 7 PLACING THE STOPPER.....	62
FIG. 8 PLACING THE PROBE.....	63
7. PH MEASURING.....	64
8.PH CALIBRATION.....	66
FIG. 9 CALIBRATION BUFFERS	66
9. <i>pH Measuring.</i>	68
10. <i>pH En/Disable</i>	68
11. <i>pH U Display</i>	68
12. <i>pH test</i>	69
1. METHOD OF DETERMINATION.	70
2. CONDUCTIVITY MEASUREMENT.....	71
3. CO METER CALIBR	71
4. CO METER TEST.	72
5. CO METER EN/DIS.	73
6.CORRECTIONS IN CONDUCTIVITY MEASUREMENT	73
7. CONDUCTIVITY CALIBRATION BUFFER PREPARATION	73

GUARANTEE CARD

LACTOSCAN SP

Standard model Wide Display

**Guarantee period is 1 (one) year after purchasing date.
Improper handling, transport and storage will invalidate the guarantee.
Guarantee is void if warranty labels are removed.**

Serial №

Date of purchase:

Password:

Distributor:

Signature:

Stamp:

GUARANTEE CARD

Purchaser:

Service report:

Service entry date	Damage	Delivery date	Signature

Covers:

Lactoscan SP

Last edited: 29.03.2019

HEAD OFFICE:

4, Narodni Buditeli Str.

8900 Nova Zagora

BULGARIA

Phone/Fax: + 359 457 67082

www.lactoscan.com

www.milkotronic.com